

NFS2-3030

Intelligent Addressable Fire Alarm System



Intelligent Fire Alarm Control Panels

General

The NFS2-3030 is an intelligent Fire Alarm Control Panel designed for medium- to large-scale facilities. Fire emergency detection and evacuation are extremely critical to life safety, and the NFS2-3030 is ideally suited for these applications. The NFS2-3030 is part of the ONYX® Series of products from NOTIFIER. The NFS2-3030 is ideal for virtually any application because it features a modular design that is configured per project requirements. With one to ten Signaling Line Circuits (SLCs), the NFS2-3030 supports up to 3,180 intelligent addressable devices.

Information is critical to fire evacuation personnel, and the NFS2-3030's large 640-character Liquid Crystal Display (LCD) presents vital information to operators concerning a fire situation, fire progression, and evacuation details.

A host of other options are available, including single- or multi-channel voice; firefighters telephone; LED, LCD, or PC-based graphic annunciators; fire or integration networking; advanced detection products for challenging environments, and many additional options.

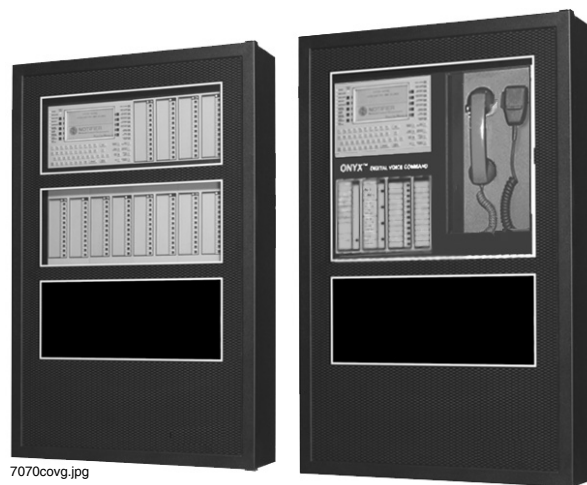

NFS2-3030s, DVC audio option at right

Features

- Certified for seismic applications when used with the appropriate seismic mounting kit.
- One to ten isolated intelligent Signaling Line Circuits (SLC) Style 4, 6 or 7.
- Up to 159 detectors and 159 modules per SLC, 318 devices per loop/3,180 per FACP or network node. Detectors can be any mix of ion, photo, laser photo, thermal, or multi-sensor detectors; modules can be addressable pull stations, normally open contact devices, two-wire smoke, notification, or relay modules.
- Large 640-character LCD backlit display (16 lines x 40 characters) or display-less (a node on a network).
- Network options:
 - High-speed network for up to 200 nodes (NFS2-3030, NFS2-640, NFS-320(C), NFS-320SYS, NCA-2, DVC, ONYXWorks, NFS-3030, NFS-640, and NCA).
 - Standard network for up to 103 nodes (NFS2-3030, NFS2-640, NFS-320(C), NFS-320SYS, NCA-2, DVC, ONYXWorks, NCS, NFS-3030, NFS-640, NCA, AFP-200, AFP-300/400, AFP-1010, and AM2020). Up to 54 nodes when DVC is used in network paging.
- Built-in Alarm, Trouble, Security, and Supervisory relays.
- VeriFire® Tools online/offline program option.
- Application code is saved in Flash memory.
- With built-in Degraded Mode operation, the system is capable of general alarm if a fire alarm condition is present even if the CPU fails.
- Weekly Occupancy Schedules allow changing sensitivity by time of day and day of week.
- EIA-485 annunciators, including custom graphics.
- History file with 4000-event capacity in nonvolatile memory, plus separate 1000-event alarm-only file.
- Advanced history filters allow sorting by event, time, date, or address.
- Alarm Verification selection per point, with tally.
- Autoprogramming and Walk Test reports.
- Multiple central station communication options:
 - Standard UDACT
 - Internet
 - Internet/GSM
- Positive Alarm Sequence (PAS) Presignal.
- Silence Inhibit and Auto Silence timer options.
- Field-programmable on panel or on PC, with VeriFire Tools program, also check, compare.
- Non-alarm points for lower priority functions.
- Remote ACK/Signal Silence/System Reset/Drill via monitor modules.
- Up to 1000 powerful Boolean logic equations.
- Supports SCS Series smoke control system in both HVAC or FSCS modes.
- FM6320 approved Gas Detection System with FMM-4-20 module and any FM listed gas detector.
- EIA-232 printer port.
- EIA-485 annunciator port.

640-CHARACTER DISPLAY FEATURES

- Backlit, 640-character display.
- Program keypad: full QWERTY keypad.
- Up to nine users, each with a password and selectable access levels.
- **11 LED indicators:** Power; Fire Alarm; Pre-Alarm; Security; Supervisory; System Trouble; Other Event; Signals Silenced; Point Disabled; CPU Failure; Controls Active.
- **Membrane Switch Controls:** Acknowledge; Signal Silence; Drill; System Reset; Lamp Test.
- **LCD Display:** 640 characters (16 x 40) with long-life LED backlight.

FLASHSCAN™ INTELLIGENT FEATURES

- Poll up to 318 devices on each loop in less than two seconds.
- Activate up to 159 outputs in less than five seconds.
- Multicolor LEDs blink device address during Walk Test.
- Fully digital, high-precision protocol (U.S. Patent 5,539,389).
- Manual sensitivity adjustment — nine levels.
- Pre-alarm ONYX intelligent sensing — nine levels.
- Sensitivity levels:
 - **Ion** – 0.5 to 2.5%/foot obscuration.
 - **Photo** – 0.5 to 2.35%/foot obscuration.
 - **Laser (VIEW®)** – 0.02 to 2.0%/foot obscuration.
 - **Acclimate Plus™** – 0.5 to 4.0%/foot obscuration.
 - **IntelliQuad** – 1.0 to 4.0%/foot obscuration.
 - **IntelliQuad™ PLUS** – 1.0 to 4.0%/foot obscuration
- Drift compensation (U.S. Patent 5,764,142).
- Multi-detector algorithm involves nearby detectors in alarm decision (U.S. Patent 5,627,515).
- Automatic detector sensitivity testing (NFPA-72 compliant).
- Maintenance alert (two levels).
- Self-optimizing pre-alarm.
- Programmable activation of sounder/relay bases during alarm or pre-alarm.
- Read Status displays the level of detector cleanliness.

FSL-751 VIEW® (VERY INTELLIGENT EARLY WARNING) SMOKE DETECTION TECHNOLOGY

- Revolutionary spot laser design.
- Advanced ONYX intelligent sensing algorithms differentiate between smoke and non-smoke signals (U.S. Patent 5,831,524).
- Addressable operation pinpoints the fire location.
- No moving parts to fail or filters to change.
- Early warning performance comparable to the best aspiration systems at a fraction of the lifetime cost.

FAPT-851 ACCLIMATE PLUS™ LOW-PROFILE INTELLIGENT MULTI-SENSOR

- Detector automatically adjusts sensitivity levels without operator intervention or programming. Sensitivity increases with heat.
- Microprocessor-based technology; combination photo and thermal technology.
- Low-temperature signal at 40°F ± 5°F (4.44°C ± 2.77°C).

FSC-851 INTELLIQUAD ADVANCED MULTI-CRITERIA DETECTOR

- Detects all four major elements of a fire (smoke, heat, CO, and flame).
- Automatic drift compensation of smoke sensor and CO cell.
- High nuisance-alarm immunity.
- Six sensitivity levels.

Sample System Options

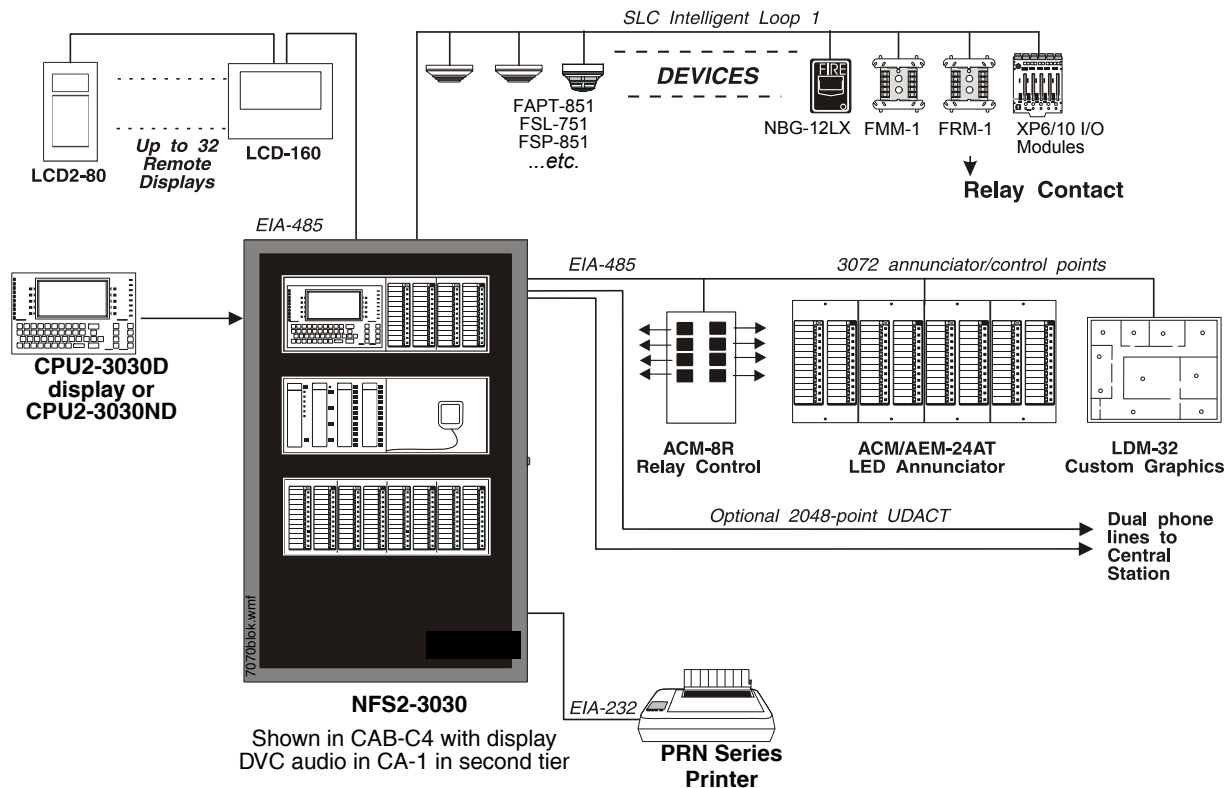

NOTE: CPU2-3030 firmware version 14.0 (and higher) can support LCD-160 on the RDP port, or LCD2-80/LCD-80 in terminal mode, but not both at the same time.

FCO-851 INTELLIQUAD™ PLUS ADVANCED MULTI-CRITERIA FIRE/CO DETECTOR

- Detects all four major elements of a fire.
- Separate signal for life-safety CO detection.
- Optional addressable sounder base for Temp-3 (fire) or Temp-4(CO) tone.
- Automatic drift compensation of smoke sensor and CO cell.
- High nuisance-alarm immunity.
- Six sensitivity levels.

FMM-4-20 GAS DETECTION MODULE

- Interface to industry-standard linear scale 4-20 mA sensors.
- Five programmable thresholds.
- FM Approved, Class 6320 (Stationary Gas Sensors/Detectors).

RELEASING FEATURES

- Ten independent hazards.
- Sophisticated cross-zone (three options).
- Delay timer and Discharge timers (adjustable).
- Abort (four options).

VOICE AND TELEPHONE FEATURES

- Up to eight channels of digital audio.
- 35 watt, 50 watt, 75 watt, and 100/125 watt digital amplifiers (DAA2/DAX series and DS series)
- Solid state message generation.
- Hard-wired voice control module options.
- Firefighter telephone option.
- 30- to 120-watt analog amplifiers (AA Series).
- Backup tone generator and amplifier option.

FlashScan® Exclusive World-Leading Detector Protocol

At the heart of the NFS2-3030 is a set of detection devices and device protocol — FlashScan (U.S. Patent 5,539,389). FlashScan is an all-digital protocol that gives superior precision and high noise immunity.

As well as giving quick identification of an active input device, this new protocol can also activate many output devices in a fraction of the time required by competitive protocols. This high speed also allows the NFS2-3030 to have the largest device per loop capacity in the industry — 318 points — yet every input and output device is sampled in less than two seconds. The microprocessor-based FlashScan® detectors have bicolor LEDs that can be coded to provide diagnostic information, such as device address during Walk Test.

ONYX Intelligent Sensing

ONYX Intelligent Sensing is a set of software algorithms that provide the NFS2-3030 with industry-leading smoke detection capability. These complex algorithms require many calculations on each reading of each detector, and are made possible by the very high-speed microcomputer used by the NFS2-3030.

Drift Compensation and Smoothing. Drift compensation allows the detector to retain its original ability to detect actual smoke, and resist false alarms, even as dirt accumulates. It reduces maintenance requirements by allowing the system to automatically perform the periodic sensitivity measurements required by NFPA 72. Smoothing filters are also provided by software to remove transient noise signals, usually caused by electrical interference.

Maintenance Warnings. When the drift compensation performed for a detector reaches a certain level, the performance of the detector may be compromised, and special warnings are given. There are three warning levels: (1) Low Chamber value; (2) Maintenance Alert, indicative of dust accumulation that is near but below the allowed limit; (3) Maintenance Urgent, indicative of dust accumulation above the allowed limit.

Sensitivity Adjust. Nine sensitivity levels are provided for alarm detection. These levels can be set manually, or can change automatically between day and night. Nine levels of pre-alarm sensitivity can also be selected, based on predetermined levels of alarm. Pre-alarm operation can be latching or self-restoring, and can be used to activate special control functions.

Self-Optimizing Pre-Alarm. Each detector may be set for “Self-Optimizing” pre-alarm. In this special mode, the detector “learns” its normal environment, measuring the peak analog readings over a long period of time, and setting the pre-alarm level just above these normal peaks.

Cooperating Multi-Detector Sensing. A patented feature of ONYX Intelligent Sensing is the ability of a smoke sensor to consider readings from nearby sensors in making alarm or pre-alarm decisions. Without statistical sacrifice in the ability to resist false alarms, it allows a sensor to increase its sensitivity to actual smoke by a factor of almost two to one.

Field Programming Options

Autoprogram. This timesaving feature is a special software route. The FACP “learns” what devices are physically connected and automatically loads them in the program with default values for all parameters. Requiring less than one minute to run, this routine allows the user to have almost immediate fire protection in a new installation, even if only a portion of the detectors are installed.

Keypad Program Edit. The NFS2-3030, like all NOTIFIER intelligent panels, has the exclusive feature of program creation and editing capability from the front panel keypad, while continuing to provide fire protection. The architecture of the NFS2-3030 software is such that each point entry carries its own program, including control-by-event links to other points. This allows the program to be entered with independent per-point segments, while the NFS2-3030 simultaneously monitors other (already installed) points for alarm conditions.

VeriFire® Tools

VeriFire® Tools is an offline programming and test utility that can greatly reduce installation programming time, and increase confidence in the site-specific software. It is Windows® based and provides technologically advanced capabilities to aid the installer. The installer may create the entire program for the NFS2-3030 in the comfort of the office, test it, store a backup file, then bring it to the site and download from a laptop into the panel.

Product Line Information

- “Configuration Guidelines” on page 4
- “Networking Options” on page 4
- “Auxiliary Power Supplies and Batteries” on page 4
- “Audio Options” on page 4
- “Compatible Devices, EIA-232 Ports” on page 5
- “Compatible Devices, EIA-485 Ports” on page 5
- “Compatible Intelligent Devices” on page 5
- “Enclosures, Chassis, and Dress Plates” on page 6
- “Other Options” on page 6

CONFIGURATION GUIDELINES

Stand-alone and network systems require a main display. On single-CPU systems (one NFS2-3030D), the display option is the CPU2-3030D. On network systems (two or more networked fire panel nodes), at least one NCA-2, NCS, or ONYX-Works annunciation device is required. Options listed as follows.

CPU2-3030D: NFS2-3030 Primary Display. CPU2-3030D ships with keypad/display installed; includes 640-character backlit LCD display, QWERTY programming and control keypad. CPU2-3030 is a central processing unit and requires an **AMPS-24(E)** power supply.

CPU2-3030ND: CPU2-3030 without display.

LCM-320: Loop Control Module. Adds SLCs to 3030; 3030 supports up to 5 LCM-320s and 5 LEM-320s. See DN-6881.

LEM-320: Loop Expander Module. Expands each LCM used on the 3030. See DN-6881.

SAMPLE SYSTEM: Four-loop NFS2-3030 with display: CPU2-3030D, DP-DISP, two BMP-1s, CHS-M3, two LCM-320s, two LEM-320s, AMPS-24, SBB-A4, DR-A4, BP2-4, BB-100, batteries.

NETWORKING OPTIONS

NCA-2: Network Control Annunciator, 640 characters. An alternate primary display for CPU2-3030 can be provided by the NCA-2, NCS, or ONYXWorks. Using NCA-2 as primary display enables non-English languages. On network systems (two or more networked fire panel nodes), one network display (either NCA-2, NCS, or ONYXWorks) is required for every system. On network systems, the NCA-2 connects (and requires) a standard Network Control Module or High-Speed Network Control Module. Mounts in a row of FACP node or in two annunciator positions. Mounting options include the DP-DISP, ADP-4B, or in an annunciator box, such as the ABS-2D. In CAB-4 top-row applications, a DP-DISP and two BMP-1 blank modules are required for mounting. See DN-6858.

NCM-W, NCM-F: Standard Network Communications Modules. Wire and multi-mode fiber versions available. See DN-6861.

HS-NCM-W/MF/SF/WMF/WSF/MFSF: High-speed network communications modules that can connect to two nodes. Wire, single-mode fiber, multi-mode fiber, and media conversion models are available. See DN-60454.

RPT-W, RPT-F, RPT-WF: Standard-network repeater board with wire connection (RPT-W), fiber connection (RPT-F), or allowing a change in media type between wire and fiber (RPT-WF). Not used with high-speed networks. See DN-6971.

ONYXWorks: UL-listed graphics PC workstation, ONYXWorks GUI software, and computer hardware. See DN-7048 for specific part numbers.

NFN-GW-EM, NFN-GW-EM-3: NFN Gateway, embedded. See DN-60499.

AUXILIARY POWER SUPPLIES AND BATTERIES

AMPS-24(E): One required for each NFS2-3030. Addressable power supply and battery charger with two 24 VDC outputs. Addressable by any FlashScan® or CLIP mode FACP. Charges 7 to 200 AH batteries. Occupies up to four addresses on an SLC, depending on configuration. Primary input power for panel. See DN-6883.

APS2-6R: Auxiliary Power Supply. Provides up to 6.0 amperes of power for peripheral devices. Includes battery input and transfer relay, and overcurrent protection. Mounts on two of four positions on a CHS-4L or CHS-4 chassis. See DN-5952.

ACPS-610: 6.0 A or 10 A addressable charging power supply. See DN-60244.

FCPS-24S6/-24S8: Remote 6 A and 8 A power supplies with battery charger. See DN-6927.

BAT Series: Batteries. AMPS-24 uses two 12 volt, 7 to 200 AH batteries. See DN-6933.

AUDIO OPTIONS

NOTE: See "Enclosures, Chassis, and Dress Plates" on page 6 for mounting hardware.

DVC-EM: Digital Voice Command, digital audio processor with message storage for up to 32 minutes of standard quality (4 minutes at high quality) digital audio. See DN-7045.

DVC-RPU: Digital Voice Command Remote Paging Unit for use with DVC-EM. Includes the keypad/display. See DN-60726.

DS-DB: Digital Series Distribution Board, provides bulk amplification capabilities to the DVC while retaining digital audio distribution capabilities. Can be configured with up to four DS-AMPs, supplying high-level risers spread throughout an installation. See DN-60565.

DVC-KD: Keypad for local annunciation and controls; status LEDs and 24 user-programmable buttons. See DN-7045.

DS-AMP/E: 125W, 25 VRMS, or 100W, 70VRMS. 70VRMS requires DS-XF70V step-up transformer. Digital Series Amplifier, part of the DS-DB system. See DN-60663.

DS-RFM, DS-FM, DS-SFM: Fiber conversion modules for DVC, DS-DB distribution board, and DAX/DAA2 Series amplifiers. See DN-60633.

DAA2-5025(E): 50W, 25 Vrms Digital Audio Amplifier assembly with power supply; includes chassis. See DN-60556.

DAA2-5070(E): 50W, 70.7 Vrms Digital Audio Amplifier assembly with power supply; includes chassis. See DN-60556.

DAA2-7525(E): 75W, 25 Vrms digital audio amplifier assembly with power supply; includes chassis. See DN-60556.

DAX-3525(E): 35W, 25 Vrms Digital Audio Amplifier assembly with power supply, includes chassis. See DN-60561.

DAX-3570(E): 35W, 70.7 Vrms Digital Audio Amplifier assembly with power supply, includes chassis. See DN-60561.

DAX-5025(E): 50W, 25 Vrms Digital Audio Amplifier assembly with power supply, includes chassis. See DN-60561.

DAX-5070(E): 50W, 70.7 Vrms Digital Audio Amplifier assembly with power supply, includes chassis. See DN-60561.

TELH-1: Firefighter's Telephone Handset for use with the DVC when mounted in the CA-2 chassis. See DN-7045.

CMIC-1: Microphone used with DVC/DVC-EM. Included with CA-2 chassis assembly. See DN-7045.

RM-1/RM-1SA: Remote microphone assemblies, mount on ADP-4 (RM-1) dress panel or CAB-RM/-RMR (RM-1SA) stand-alone cabinets. See DN-6728.

FTM-1: Firephone Control Module connects a remote firefighter telephone to a centralized telephone console. Reports status to panel. Wiring to jacks and handsets is supervised. See DN-6989.

AA-30: Audio Amplifier, 30 watts. Switch-mode power. Includes amplifier and audio input supervision, backup input, and automatic switchover, power supply, cables. See DN-3224.

AA-120/AA-100: Audio Amplifier provides up to 120 watts of 25 Vrms audio power. The amplifier contains an integral chassis for mounting to a CAB-B4, -C4, or -D4 backbox (consumes one row). Switch-mode power. Includes audio input and amplified output supervision, backup input, and automatic switchover to backup tone. Order the AA-100 for 70.7 Vrms systems and 100 watts of power. See DN-3224.

DAA Series Digital Audio Amplifiers: Legacy DAA Series amplifiers are compatible with DVC systems running SR4.0. For specific information on DAA-50 series amplifiers, refer to DN-7046. For information on DAA-7525 Series, refer to DN-60257.

COMPATIBLE DEVICES, EIA-232 PORTS

PRN-6: 80-column printer. *See DN-6956.*

VS4095/5: Printer, 40-column, 24 V. Order from Keltron, Inc. *See DN-3260.*

DPI-232: Direct Panel Interface, specialized modem for extending serial data links to remotely located FACPs and/or peripherals. *See DN-6870.*

COMPATIBLE DEVICES, EIA-485 PORTS

ACM-24AT: ONYX® Series ACS annunciator – up to 96 points of annunciation with Alarm or Active LED, Trouble LED, and switch per circuit. Active/Alarm LEDs can be programmed (by powered-up switch selection) by point to be red, green, or yellow; the Trouble LED is always yellow. *See DN-6862.*

AEM-24AT: Same LED and switch capabilities as ACM-24AT; expands the ACM-24AT to 48, 72, or 96 points. *See DN-6862.*

ACM-48A: ONYX® Series ACS annunciator – up to 96 points of annunciation with Alarm or Active LED per circuit. Active/Alarm LEDs can be programmed (by powered-up switch selection) in groups of 24 to be red, green, or yellow. Expandable to 96 points with one AEM-48A. *See DN-6862.*

AEM-48A: Same LED capabilities as ACM-48A; expands the ACM-48A to 96 points. *See DN-6862.*

ACM-8R: Remote Relay Module with eight Form-C contacts. Can be located up to 6,000 ft. (1828.8 m) from panel on four wires. *See DN-3558.*

LCD-160: Liquid Crystal Display annunciator, 160-character backlit. Can store character sets for multiple languages. Supports Canadian requirements. *See DN-6940*

LCD-80: ACS mode. 80-character, backlit LCD display. Mounts up to 6,000 ft. (1828.8 m) from panel. Up to 32 per FACP. *See DN-3198.*

LCD2-80: Terminal mode. 80-character, backlit LCD display. Mounts up to 6,000 ft. (1828.8 m) from panel. Up to 32 per FACP. *See LCD2-80 (DN-60548).*

SCS Series: Smoke control station; eight (expandable to 16) circuits. *See DN-4818.*

TM-4: Transmitter Module. Includes three reverse-polarity circuits and one municipal box circuit. Mounts in panel module position (as in single-address mode applications) or in CHS-M3 position. *See DN-6860.*

UDACT: Universal Digital Alarm Communicator Transmitter, 636 channel *See DN-4867.*

UDACT-2: Universal Digital Alarm Communicator Transmitter, 636 channel. *See DN-60686.*

UZZ-256: Programmable Universal Zone Coder provides positive non-interfering successive zone coding. Microprocessor-controlled, field-programmable from IBM®-compatible PCs (*requires optional programming kit*). Mounts on a CHS-4 series chassis within NFS2-3030.

COMPATIBLE INTELLIGENT DEVICES

BEAMHK: Heating kit for transmitter/receiver unit of FSB-200(S) below. *See DN-6985.*

BEAMHKR: Heating kit for use with the reflector of FSB-200(S) below. *See DN-6985.*

BEAMLRK: Long-range accessory kit, FSB-200(S) below. *See DN-6985.*

BEAMMRK: Multi-mount kit, FSB-200(S) below. *See DN-6985.*

BEAMSMK: Surface-mount kit, FSB-200(S) below. *See DN-6985.*

FSB-200: Intelligent beam smoke detector. *See DN-6985.*

FSB-200S: Intelligent beam smoke detector with integral sensitivity test. *See DN-6985.*

FSC-851: FlashScan IntelliQuad Advanced Multi-Criteria Detector. *See DN-60412.*

FCO-851: FlashScan IntelliQuad PLUS Advanced Multi-Criteria Fire/CO Detector. *See DN-60689.*

FSI-851: Low-profile FlashScan ionization detector. *See DN-6985.*

FSP-851: Low-profile FlashScan photoelectric detector. *See DN-6935.*

FSP-851R: Low-profile intelligent photoelectric sensor, remote test capable. For use with DNR(W). *See DN-6935.*

FSP-851T: Low-profile FlashScan photoelectric detector with 135°F (57°C) thermal. *See DN-6935.*

FST-851: FlashScan thermal detector 135°F (57°C). *See DN-6936.*

FST-851R: FlashScan thermal detector 135°F (57°C) with rate-of-rise. *See DN-6936.*

FST-851H: FlashScan 190°F (88°C) high-temperature thermal detector. *See DN-6936.*

FAPT-851: FlashScan Acclimate Plus™ low-profile multi-sensor detector. *See DN-6937.*

FSL-751: FlashScan VIEW® laser photo detector. *See DN-6886.*

DNR: InnovairFlex low-flow non-relay duct-detector housing (order FSP-851 separately). Replaces FSD-751PL/FSD-751RPL. *See DN-60429.*

DNRW: Same as above with NEMA-4 rating, watertight. *See DN-60429.*

B224RB: Low-profile relay base. *See DN-60054.*

B224BI: Isolator base for low-profile detectors. *See DN-60054.*

B210LP: Low-profile base. Standard U.S. style. Replaces B710LP. *See DN-60054.*

B501: European-style, 4" (10.16 cm) base. *See DN-60054.*

B200S: Intelligent programmable sounder base, capable of producing a variety of tone patterns including ANSI Temporal 3. Compatible with synchronization protocol. *See DN-60054.*

B200SR: Sounder base, Temporal 3 or Continuous tone. *See DN-60054.*

FMM-1: FlashScan monitor module. *See DN-6720.*

FDM-1: FlashScan dual monitor module. *See DN-6720.*

FZM-1: FlashScan two-wire detector monitor module. *See DN-6720.*

FMM-101: FlashScan miniature monitor module. *See DN-6720.*

FMM-4-20: FlashScan 4-20 mA protocol monitor module. *See DN-60411.*

FCM-1: FlashScan NAC control module. *See DN-6724.*

FCM-1-REL: FlashScan releasing control module. *See DN-60390.*

FRM-1: FlashScan relay module. *See DN-6724.*

FDRM-1: FlashScan dual monitor/dual relay module. See DN-60709.

NBG-12LX: Manual pull station, addressable. See DN-6726.

ISO-X: Isolator module. See DN-2243.

XP6-C: FlashScan six-circuit supervised control module. See DN-6924.

XP6-MA: FlashScan six-zone interface module; connects intelligent alarm system to two-wire conventional detection zone. See DN-6925.

XP6-R: FlashScan six-relay (Form-C) control module. See DN-6926.

XP10-M: FlashScan ten-input monitor module. See DN-6923.

ENCLOSURES, CHASSIS, AND DRESS PLATES

CAB-4 Series Enclosure: NFS2-3030 mounts in a standard CAB-4 Series enclosure (available in four sizes, "A" through "D"). Backbox and door ordered separately; requires BP2-4 battery plate. A trim ring option is available for semi-flush mounting. See DN-6857.

EQ Series Cabinets: EQ series cabinets will house amplifiers, power supplies, battery chargers and control modules. EQ cabinets are available in three sizes, "B" through "D". See DN-60229.

CHS-M3: Mounting chassis for CPU2-3030. One required for each CPU2-3030D/3030ND.

CA-2: Chassis for CPU when DVC is used with firefighter's telephone. Mounts in the top two rows of a CAB-4 series enclosure.

DP-DISP: Dress panel for top row in cabinet with CPU2-3030D installed.

DP-1B: Blank dress panel. Provides dead-front panel for unused tiers; covers DAA2-series or AA-series amplifier. See DN-7046.

CHS-BH1: Battery chassis; holds two 12.0 AH batteries. Mounts on the left side of DAA2 chassis. See DN-7046.

CA-1: Chassis, occupies one tier of a CAB-4 Series enclosure. The left side accommodates one DVC and a DVC-KD (optional); and the right side houses a CMIC-1 microphone and its well (optional). See DN-7045.

CA-2: Chassis assembly, occupies two tiers of a CAB-4 Series enclosure. The left side accommodates one DVC mounted on a half-chassis and one NFS2-3030 or NCA-2 mounted on a half-chassis. The right side houses a microphone/handset well. The CA-2 assembly includes CMIC-1 microphone. ADDR Series doors with two-tier visibility are available for use with the CA-2 configuration: ADDR-B4, ADDR-C4, ADDR-D4 (below).

ADDR-B4: Two-tier-sized door designed for use with the CA-2 chassis configuration. ADDR Series doors are similar to CAB-4 Series "DR" doors, but a clear window space exposes the top two tiers of the CAB-4 enclosure. Use an SBB-B4 backbox with the ADDR-B4. See DN-7045, DN-6857.

ADDR-C4: Three-tier-sized door designed for use with the CA-2 chassis configuration. ADDR Series doors are similar to CAB-4 Series "DR" doors, but a clear window space exposes the top two tiers of the CAB-4 enclosure. Use an SBB-C4 backbox with the ADDR-C4. See DN-7045, DN-6857.

ADDR-D4: Four-tier-sized door designed for use with the CA-2 chassis configuration. ADDR Series doors are similar to CAB-4 Series "DR" doors, but a clear window space exposes the top two tiers of the CAB-4 enclosure. Use an SBB-D4 backbox with the ADDR-D4. See DN-7045, DN-6857.

DPA-1: Dress panel, used with the CA-1 chassis when configured with a DVC, DVC-KD, and CMIC-1. See DN-7045.

DPA-2: Dress Panel used with the CA-2 chassis assembly.

DPA-1A4: Dress panel, used with the CA-1 chassis when the CMIC-1 is not used. Provides mounting options on right two bays for two ACS annunciators, or for blank plates. See DN-7045.

ADP-4B: Annunciator dress plate. Mounts in rows 2, 3 or 4 of a CAB-4 series enclosure. Used with ACS series annunciators.

BMP-1: Blank module for unused module positions.

DP-1B: Blank dress panel. Provides dead-front panel for unused tiers; covers DAA2-series or AA-series amplifier.

BP2-4: Battery plate, required.

CHS-4L: Low-profile four-position Chassis. Mounts two AA-30 amplifiers.

CHS-4N: Chassis for mounting up to four APS-6Rs.

CHS-6: Chassis used with the XP6 and XP10 Multi-Modules. Mounts up to six modules in any CAB-4 series row.

BB-100: Backbox for batteries and power supplies. The BB-100 is used to mount up to two 100-AH batteries and power supply, if needed. 30" (76.20 cm) wide x 25" (63.50 cm) high x 7.5" (19.05 cm) deep; depth includes door.

BB-200: Backbox for batteries and power supplies. Holds the AMPS-24(E) power supply when AMPS-24(E) is used as a charger for 200 AH batteries. Holds up to four 100 AH batteries and power supply. 30" (76.20 cm) wide x 36" (91.44 cm) high x 7.5" (19.05 cm) deep; depth includes door.

NFS-LBB: Battery Box. The NFS-LBB is used to mount up to two 55-AH batteries. Dimensions: Box: 24" (610 mm) wide x 14" (356 mm) high x 7.75" (197 mm) deep. Door: 24.125" (613 mm) wide x 14.25" (362 mm) high; door adds 0.0625" (approx. 1.6 mm) to depth.

BB-UZC: Backbox for housing the UZC-256 for applications where the UZC will not fit in panel enclosure. Black; for red, order BB-UZC-R. See DN-3404.

SEISKIT-CAB: Seismic mounting kit. Required for seismic-certified applications with NFS2-3030 and other equipment mounted in CAB-4 Series Enclosures. Includes battery bracket for two batteries up to 26 AH.

SEISKIT-320/B26: Seismic mounting kit. Required for seismic-certified applications with BB-26. Includes battery bracket for two 26 AH batteries.

SEISKIT-LBB: Seismic kit for the NFS-LBB. Includes battery bracket for two 55 AH batteries.

SEISKIT-PS/2/4: Seismic mounting kit for the FCPS-24S6/S8 and CAB-PS1. Includes battery bracket for two 7 AH or 12 AH batteries.

OTHER OPTIONS

411: Slave digital alarm communicator. See DN-6619.

411UDAC: Digital alarm communicator. See DN-6746.

IPDACT-2, IPDACT Internet Monitoring Module: Connects to primary and secondary DACT telephone output ports for internet communications over customer-provided ethernet connection. Requires compatible Teldat VisorALARM Central Station Receiver. Can use DHCP or static IP. See DN-60408.

IPCHSKIT: IP Communicator Chassis Mounting Kit. For mounting an IPDACT-2/2UD onto the panel chassis or CHS-4 series chassis. Use IPENC for external mounting applications.

IPSPLT: Y-adaptor option allow connection of both panel dialer outputs to one IPDACT-2/2UD cable input.

IPENC: External enclosure for IPDACT, includes IPBRKT mounting bracket; Red; for black, order IPENC-B.

IPGSM-DP: Internet and Digital Cellular Fire Alarm Communicator. Provides selectable configurable paths: cellular only, IP only, or IP primary with cellular backup. Connects to the primary and secondary ports of a DACT. Replaces IPGSM-COM. See *DH-60695*.

NOTE: For other options including compatibility with retrofit equipment, refer to the panel's installation manual, the SLC manual, and the Device Compatibility Document.

SYSTEM SPECIFICATIONS

System Capacity

- Intelligent Signaling Line Circuits1 expandable to 10
- Intelligent detectors 159 per loop
- Addressable monitor/control modules 159 per loop
- Programmable software zones over 2000
- ACS annunciators
per CPU2-303032 address x 64 or 96 points
NOTE: The CPU2-3030 can support up to 96 annunciator address points per ACM-24/-48.

Specifications

- **Primary input power:**
 - **AMPS-24:** 110-120 VAC, 50/60 Hz, 4.5 A maximum.
 - **AMPS-24E:** 240 VAC, 50/60 Hz, 2.25 A maximum.
- **DC output:**
 - Main 24 VDC: Up to 5.0 A
 - Aux 24 VDC: Up to 5.0 A
 - 5 VDC: Up to 0.15 A.**NOTE:** For details of DC output values, see manual 51907.
- **Battery charger range:** 7 AH – 200 AH. Use separate cabinet for batteries over 26 AH.
- **Float Rate:** 27.6 V.

Shipping Weight

- CPU2-3030D: 5.95 lb (2.70 kg).
- CPU2-3030ND: 2.90 lb (1.32 kg).

Temperature and Humidity Ranges

This system meets NFPA requirements for operation at 0 – 49°C/32 – 120°F and at a relative humidity 93% ± 2% RH (noncondensing) at 32°C ± 2°C (90°F ± 3°F). However, the useful life of the system's standby batteries and the electronic components may be adversely affected by extreme temperature ranges and humidity. Therefore, it is recommended that this system and its peripherals be installed in an environment with a normal room temperature of 15 – 27°C/60 – 80°F.

Agency Listings and Approvals

These listings and approvals apply to the modules specified in this document. In some cases, certain modules or applications may not be listed by certain approval agencies, or listing may be in process. Consult factory for latest listing status.

- **UL Listed:** S635.
- **ULC Listed:** S635.
- **MEA:** 232-06-E.
- **FDNY:** COA#6114.
- **CSFM:** 7165-0028:0224 (Commercial).
- **FM Approved.**
- **FM6320 Approved.** Class 6320 for Gas Detection.
- **City of Chicago.**
- **City of Denver.**
- **PSB Corporation.**
- **CCCF listed.**
- **Fire Services Department (Hong Kong).**

Standards

The NFS2-3030 complies with the following UL Standards and NFPA 72, IBC, and CBC Fire Alarm Systems requirements:

- **UL 864** (Fire).
- **UL 1076** (Burglary).
- **LOCAL** (Automatic, Manual, Waterflow and Sprinkler Supervisory).
- **AUXILIARY** (Automatic, Manual and Waterflow) (requires TM-4).
- **REMOTE STATION** (Automatic, Manual, Waterflow and Sprinkler Supervisory) (requires TM-4).
- **PROPRIETARY** (Automatic, Manual, Waterflow and Sprinkler Supervisory). *Not applicable for FM.*
- **EMERGENCY VOICE/ALARM.**
- **OT, PSDN** (Other Technologies, Packet-switched Data Network).
- **IBC 2000, IBC 2003, IBC 2006, IBC2009** (Seismic).
- **CBC 2007** (Seismic).

IntelliQuad™ and NOTIFIRE-NET™ are all trademarks; and Acclimate® Plus™, FlashScan®, NOTIFIER®, ONYX®, VeriFire®, and VIEW® are all registered trademarks of Honeywell International Inc. ©2012 by Honeywell International Inc. All rights reserved. Unauthorized use of this document is strictly prohibited.



This document is not intended to be used for installation purposes.
We try to keep our product information up-to-date and accurate.
We cannot cover all specific applications or anticipate all requirements.
All specifications are subject to change without notice.



Made in the U.S. A.

For more information, contact Notifier. Phone: (203) 484-7161, FAX: (203) 484-7118.
www.notifier.com